

356 Speedster Replica Owners Manual

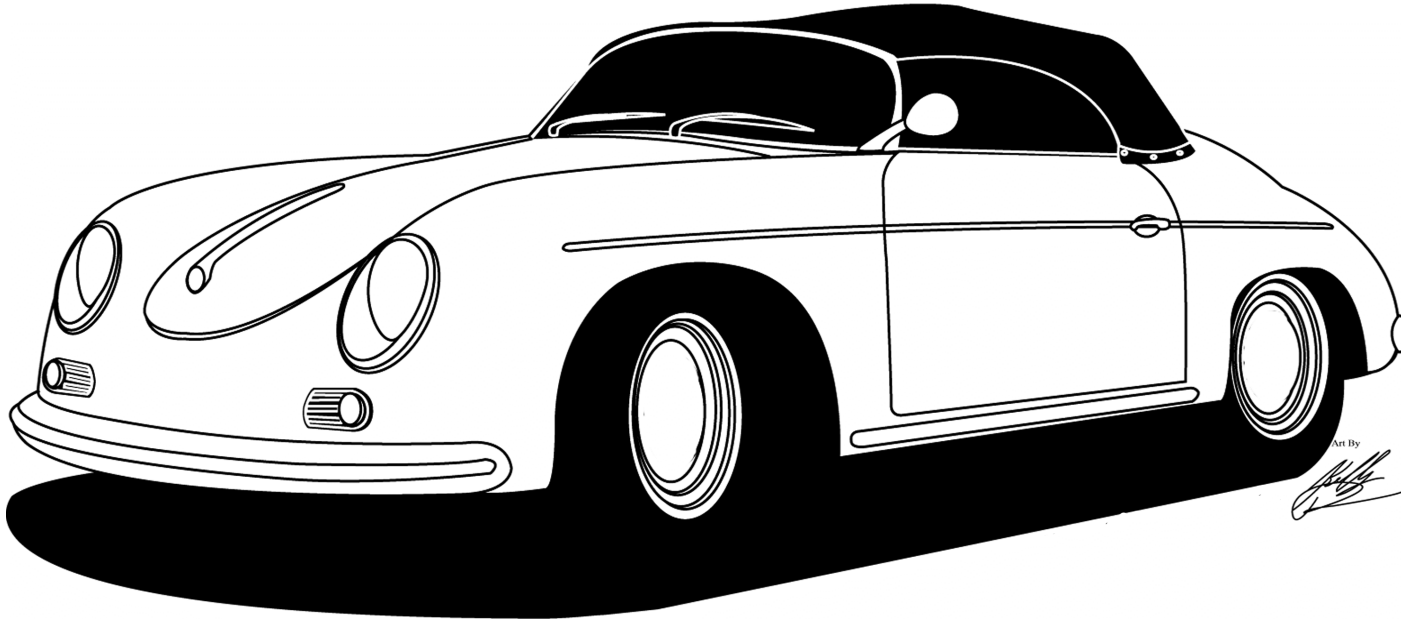

Vintage Speedsters, Inc

356 Speedster Replica Owners Manual

Congratulations on your choice of a Vintage Speedster

In this Owner's Manual you will find important information concerning operating instructions, maintenance and vehicle care.

Please keep in mind that regular care and maintenance are necessary for the operational safety of your vehicle as well as to maintain its resale value.

Depending on the options installed in your car, further Owner's Manual supplements may be provided.

We wish you many years of enjoyable driving,
Vintage Speedsters, Inc.

Operating Instructions

Dashboard and Instrument Layout

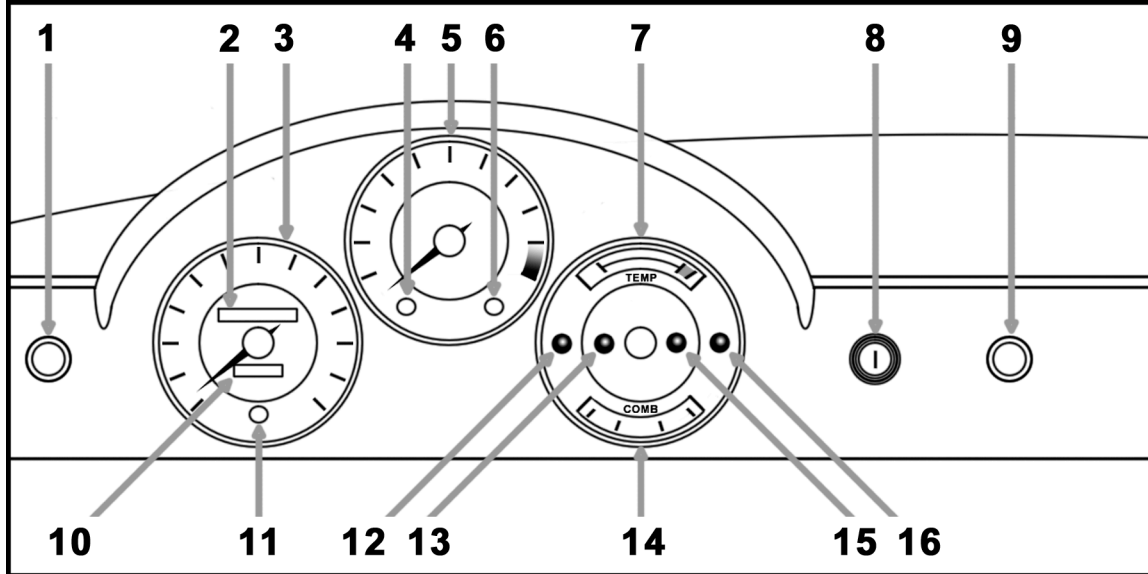

Dashboard and Instrument Layout (continued)

- 1 – Headlight Switch
- 2 – Odometer
- 3 – Speedometer
- 4 – Low Oil Pressure Warning Light
- 5 – Tachometer
- 6 – Ignition Light
- 7 – Temperature Indicator
- 8 – Ignition
- 9 – Windshield Wiper Switch (2-Speed)
- 10 – Trip Meter
- 11 – Trip Reset Button
- 12 – Not Used
- 13 – Not Used
- 14 – Fuel Level Indicator
- 15 – Not Used
- 16 – High Beam Light

Heater

The standard Speedster is equipped with a heater. Vents are located on the kick-panels, in the passenger compartment. Heat is produced only when the engine is warm. To turn on the heater, slide open the chrome vents. Next, locate the knob or lever next to the emergency brake. You will need to either turn the knob or pull up on the lever, to start to flow of heat into the passenger compartment.

Opening the Bonnet

A knob is located under the dash just below and to the left of the steering wheel. Firmly pulling the knob will release the bonnet latch to its safety position. To fully open the bonnet, stand at the front of the car, place your fingers under the bonnet and pull up on the latch. While holding the bonnet open, lift the support rod, located on the drivers side of the bonnet compartment, so that it is in a vertical position and place it into the depression on the reverse side of the bonnet.

Opening the Engine Compartment

A knob is located on the rear of the driver's doorsill. Firmly pulling the knob will release the engine compartment lid. Lift the lid and hold it in an upright position. Locate the steel pin dangling on a chain near the lid hinge. Place the pin into the hole and through the hinge to hold open the engine compartment lid. Never operate the vehicle with the engine compartment lid in its fully open position.

Maintenance

The following maintenance recommendations may NOT apply to your engine. These are general recommendations. Some engines, especially custom configurations, require different procedures.

The standard Vintage Speedster is based on the original Volkswagen beetle technology. It is recommended that each owner purchase a Volkswagen maintenance manual. The following manuals will cover general maintenance of your Volkswagen air-cooled engine.

Chilton 70200 – Volkswagen Air-Cooled 1949-69 Repair Manual

by Chilton

ISBN 0-8019-9073-4

-

How to Keep Your Volkswagen Alive

by John Muir

ISBN 1-56691-310-1

-

VW Beetle & Karmann Ghia 1954 through 1979 All Models (Hayne's Repair Manual)

by John Harold Haynes

ISBN 1-8501-0729-7

Oil Change

The engine oil should be changed at 3 months or 3000 mile intervals, whichever comes first. Most engines use the traditional style oil sump strainer.

Valve Adjustment

Engines equipped with standard valves, should have the valves adjusted every 3000 miles or when needed. With the engine temperature cold, valve clearance should be set to .006

Tire Pressure

The recommended tire pressure for your Speedster is 22psi front and 22psi back. Tire pressure should be check and regulated every 600 miles.

Ignition and Timing

Engine timing should be checked every 3000 miles, unless otherwise indicated. Follow one of the recommended Volkswagen maintenance manual instructions regarding ignition and timing. Recommendations for the 1972 Volkswagen model year can be followed.

Specifications

Gasoline Octane ----- 87-91
Oil Type ----- 30w
Tire Size ----- 165-65-R15 or 185-60-R15
Tire Pressure ----- 22psi
Valve Clearance ----- .006
Distributor ----- Bosch 009

Notes

Copyright © 2003-2012 Vintage Speedsters, Inc. ALL RIGHTS RESERVED

Vintage Speedsters, Inc. and/or other Vintage Speedsters, Inc. products referenced herein may be either trademarks or registered trademarks of Vintage Speedsters, Inc. VW and Volkswagen are registered trademarks of Volkswagen of America, Inc. Bosch is a registered trademark of Robert BOSCH Corporation. Other product and company names mentioned herein may be the trademarks or registered trademarks of their respective owners.

Product specifications are subject to change without notice.

Vintage Speedsters, Inc.
12112 Centralia Rd
Hawaiian Gardens, CA 90716 USA
1-562-402-4334
www.VintageSpeedsters.com

This manual reproduced with written permission by www.SpeedsterOwners.com